

WET MANUAL CORN KNIFE SHARPENER (WMKS)

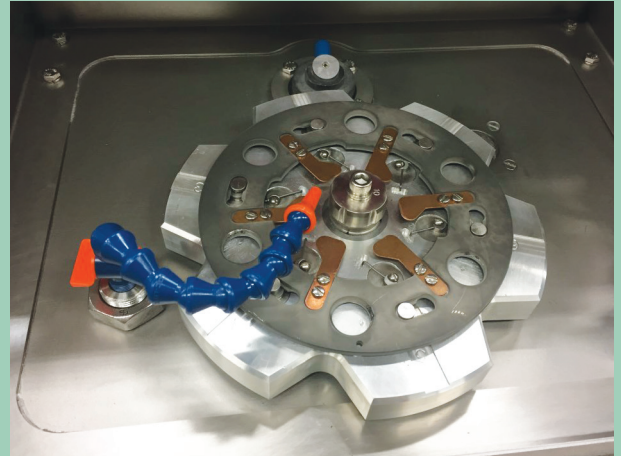

magnuson
corporation

CCM
COMPUTER CONTROLLED MACHINES



>
WMKS
Turntable

The WMKS is free-standing and comes with a grind wheel dresser, liquid-filled cooling reservoir, grind motor tilt assy, lubrication oil pump, safety interlocks, and operating controls. Features:

- Sharpens all 6 knives at the same time
- Correct knife contour allows ears to “slip” through the cutter head with minimal resistance.
- Simple to operate, and easy to maintain.

MORE FEATURES:

- **Precision** - exact knife radius and angle are locked in creating precision grind to achieve better quality of cut.
- **Advantage** - wet grinding of knife tips reduces the knife edge temperature, producing a better edge and increases knife life.
- **Functionality** - the grind angle can be set for 8, 10 or 12 degrees
- **Power requirement** - 110V / 220V, 1 PH, 50 HZ / 60HZ



Magnuson Corporation - CCM
P.O. Box 590 • 1 Magnuson Ave.
Pueblo, Colorado 81002
(719) 948-9500 • FAX (719) 948-9540
www.magnusoncorp.com

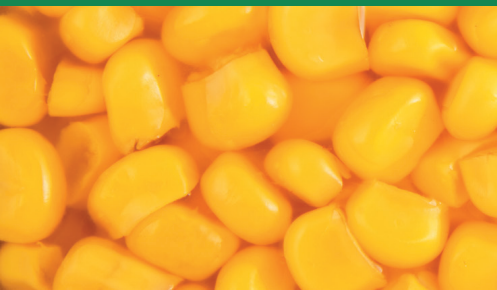



WET MANUAL CORN KNIFE SHARPENER (WMKS)

P.O. Box 590 • 1 Magnuson Ave. • Pueblo, Colorado 81002
 (719) 948-9500 • FAX (719) 948-9540 • www.magnusoncorp.com



> WMKS
Grind Motor
Tilt Assy

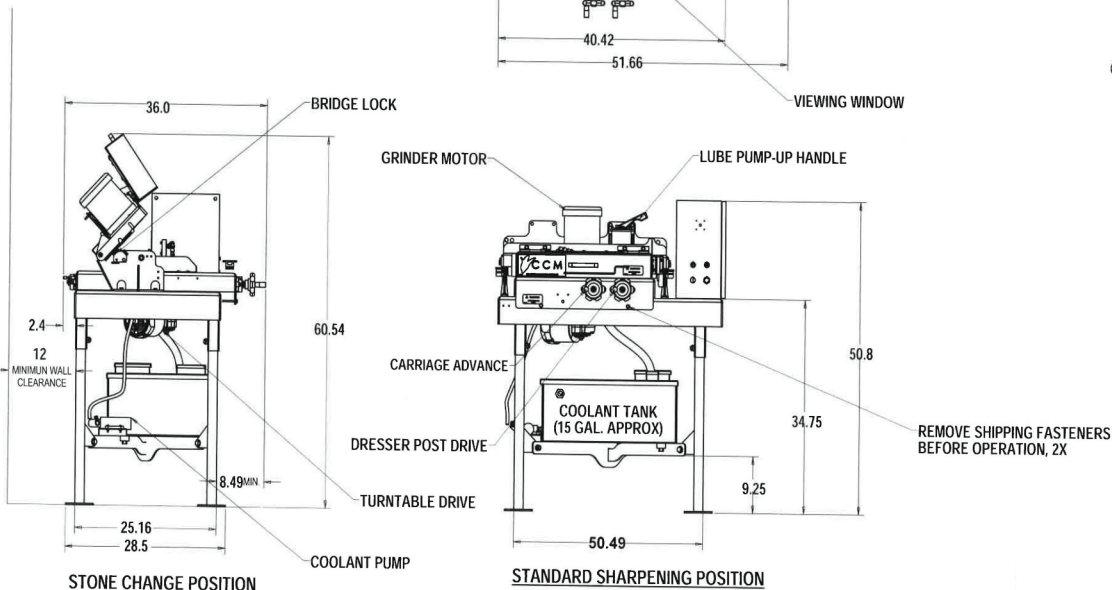
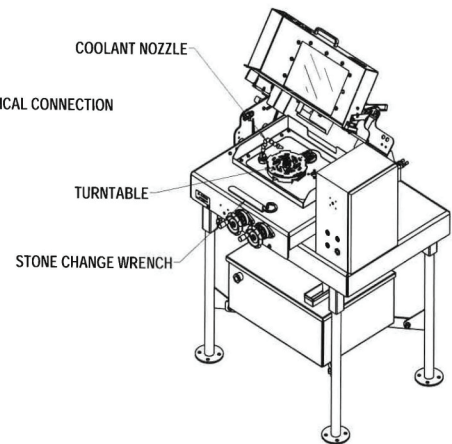
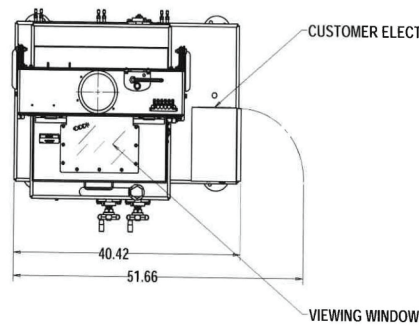

POWER REQUIREMENTS
110/220 VOLT AC - 1 PHASE
50/60 Hz